



Comparison of Organic Fertilizers on the Optimization of Growth and Yield Parameters of Lettuce (*Lactuca sativa* L.) in the City of Daloa

Moreto Salla ^{a*}, Zoumana Konate ^a,
Elisabeth Tossimidé Hougbedji ^b, Djaha Kouame ^a
and Victoire Annick Koulibaly ^a

^a Université Jean Lorougnon Guédé, UFR Agroforesterie, BP-150, Daloa, Côte d'Ivoire.

^b Centre de Recherche Agronomique du Littoral, Institut Togolais de Recherche Agronomie, BP-1163, Togo.

Authors' contributions

This work was carried out in collaboration among all authors. All authors read and approved the final manuscript.

Article Information

DOI: 10.9734/JAERI/2023/v24i5536

Open Peer Review History:

This journal follows the Advanced Open Peer Review policy. Identity of the Reviewers, Editor(s) and additional Reviewers, peer review comments, different versions of the manuscript, comments of the editors, etc are available here: <https://www.sdiarticle5.com/review-history/98737>

Short Research Article

Received: 15/02/2023

Accepted: 17/04/2023

Published: 24/04/2023

ABSTRACT

This trial was conducted on an experimental plot of the Jean Lorougnon Guédé University in Daloa (Ivory Coast). The experiment was conducted on "the comparison of the effects of organic fertilizers based on *Tithonia diversifolia* and *Thevetianeriifolia* on the optimization of growth and yield parameters of lettuce (*Lactuca sativa* L.)". Four treatments were tested in completely randomized Fisher blocks, with three repetitions. The results obtained on the growth and yield parameters considered were significantly influenced by the treatments applied. Data were collected every seven days for growth parameters and only once for post-harvest yield. Liquid treatments gave the

*Corresponding author: E-mail: salla.moreto@yahoo.fr, salla.moreto@gmail.com;

best results on height (12.96 centimeters) with *Thevetia*, number of leaves (8.91) with *Thevetia*, width of leaves (5.79 centimeters), length of leaves (8.10 centimeter) with *Tithonia* and the wingspan (11.15 centimeter) of the lettuce plants, as well as on the yield. The treatments significantly influenced growth and yield parameters.

Keywords: Market gardening; *Lactuca sativa*; biofertilizers; *Tithoniadiversifolia*; yield.

1. INTRODUCTION

The current world population of 7.6 billion is expected to reach 9.8 billion in 2050 [1]. This global population is expected to become increasingly urban. However, the practice of urban and peri-urban agriculture, especially market gardening in Africa, involves increasingly reduced spaces due to strong demographic pressure and the growing demand for building land [2]. The consequence of this pressure is the degradation of market garden soils leading to their decline in fertility and productivity [3]. The use of chemical fertilizers, due to their immediate action on crop productivity, has been considered as one of the solutions to compensate for the loss of fertilizing elements removed by harvests [4].

However, the high cost of these chemical fertilizers makes them almost inaccessible to small farmers [5]. In addition, the long-term effects of these chemical fertilizers on the quality of the environment are detrimental [6]. To this end, it seems interesting to promote the use of organic fertilizers in order to sustainably intensify market gardening. Indeed, these organic fertilizers are less expensive, easily accessible and less dangerous for the environment. Among these organic fertilizers, amendments based on *Tithoniadiversifolia* [7] and *Thevetianeriifolia* offer new prospects for reversing the trend of a significant decline in the fertility of market garden soils and the excessive use of chemical fertilizers.

While many studies have been conducted on the use of *Tithoniadiversifolia* in soil fertilization for certain crops [8,9], there are not many for *Thevetianeriifolia* [10], to name only these authors. However, these two plants have been little or almost not valued as fertilizer in agriculture in Côte d'Ivoire [10]. In addition, they are abundant in the locality of the study, especially in the rainy season for *Tithonia diversifolia* and in all seasons even for *Thevetia neriifolia*. This study was undertaken in order to valorize waste from clearing and pruning of living hedges, which are respectively *Tithonia*

diversifolia and *Thevetia neriifolia*, in order to improve the fertility of market garden soils. These plant materials are available in the locality of Daloa.

2. MATERIALS AND METHODS

2.1 Materials

2.1.1 Experimental environment

The trial was conducted on an experimental plot located on the site of the Jean Lorougnon Guédé University (UJLoG) in Daloa. Daloa is a city in the center-west of Côte d'Ivoire. It is the capital of the Haut-Sassandra department and region (Fig. 1), located 141 km from Yamoussoukro (political capital of the country) and 383 km from Abidjan (economic capital). The department of Daloa is bordered to the north by that of Vavoua, to the south by that of Issia, to the east by that of Zuénoula and Bouaflé and to the west by the department of Duékoué [11].

The vegetation of the area was originally dense semi-deciduous forest. The soils are ferrallitic. They have good agricultural aptitudes for all types of crops [12]. The climate, of the humid tropical type, has four seasons: a long rainy season with stormy inter-seasons (April to mid-July), a short dry season (mid-July to mid-September), a short rainy season (mid-September to November) and a long dry season from December to March [13].

2.1.2 Plant material

Lettuce plants grown from seeds of the "Technisem brand Impact variety" purchased commercially and four weeks old after sowing were used to test the fertilizers produced.

2.1.3 Fertilizing material

The fertilizers were obtained from the leaves of *Tithoniadiversifolia* and *Thevetianeriifolia* (Fig. 2).

The leaves of *Tithoniadiversifolia* have been used in two forms: liquid (slurry) and solid (fresh chopped leaves). Those of *Thevetianeriifolia* were used in a single form: liquid (slurry):

- For the preparation of fresh Tithonia, the fresh leaves of *Tithoniadiversifolia* were harvested then chopped into a thin strip and incorporated directly into the soil of the beds concerned by this treatment.
- The production of liquid Tithonia first consisted of harvesting the fresh leaves of *Tithoniadiversifolia*, then cutting them up (chopping). The chopped leaves were then put in a container due to 1 kg per 10 liters of water. The mixture was closed and left to decompose for ten days protected from light.
- The preparation of liquid Thevetia (slurry) from the leaves of *Thevetianeriifolia* followed the same process as that of liquid Tithonia.

2.2 Methods

2.2.1 Establishment

Before transplanting, the lettuce seeds remained for four weeks in the nursery. Seedlings with 3 to 5 well-opened and vigorous leaves were picked and transplanted on beds for 6 to 8 weeks. The transplanting due to 24 plants per bed was carried out in the evening. At the end of transplanting, the transplanted plants were suitably watered before transplanting.

The contribution of organic fertilizers was made before and after transplanting the seedlings according to the experimental device in blocks of Fisher.

2.2.2 Experimental apparatus

A completely randomized Fisher block device with 4 treatments and 4 repetitions (i.e. 16 boards) was used (Fig. 3). The treatments applied are presented as follows:

- W0: control treatment (without adding fertilizer to the soil);
- FTd: contribution to the soil of fresh chopped leaves of *Tithoniadiversifolia*;
- TdL: supply of liquid manure based on *Tithoniadiversifolia* leaves;
- TnL: supply of liquid manure based on *Thevetianeriifolia* leaves.

2.2.3 Cultivation maintenance

Each biofertilizer was added three times during lettuce cultivation. The first additions were made one week before transplanting in basal fertilization. The other two contributions were made as a cover after transplanting. The quantities and periods of application of fertilizers to crops are recorded in Table 1 below.

The beds were watered twice a day from transplanting (morning and evening). The hoeing and weeding of the alleys were carried out once a month throughout the crop cycle. This made it possible to effectively control weeds and loosen the soil for good aeration and water infiltration.

2.2.4 Collection of data

The growth parameters, on which the observations focused, are the height of the plants, the width of the leaf, the number of leaves per plant and the wingspan of the plant [14]. These parameters were measured during the dry season maintaining, for each measurement, an interval of seven days (one week) from the second week after transplanting. The measurements were taken on fifteen choice lettuce plants in the center of the plot at random at the start per bed and per treatment (i.e. 45 plants considered per treatment).

Seven weeks after transplanting, 8 plants were harvested randomly per bed (i.e. 32 plants/treatment) then weighed using a precision electronic scale. The mass obtained was used to calculate the yield as follows:

2.2.5 Statistical analyzes of data

The data during the present study were encoded using the Excel 2016 spreadsheet. Subsequently, the statistical analyzes were carried out using the STATISTICA 7.1 software. and the differences were considered significant at the level of $\alpha = 0.05$ ($p < 0.05$) for all tests performed. All the variables were first subjected to the Shapiro-Wilk and Levene tests in order to check respectively the normality and the homogeneity of the variances of each variable. The Kruskal-Wallis test was applied to the data which did not follow the normal distribution (Shapiro-Wilk test, $p > 0.05$) to assess the significance of the effect of the treatments applied on the growth parameters of the plants. . When this is significant ($p < 0.05$), the Mann-Whitney rank comparison test is then performed to determine the specific differences between the variables taken two by two. The analysis of variances with one classification criterion (ANOVA) was applied to the variables which followed the normal law to estimate the significance of their variations. Finally, the ANOVA was accompanied by Fisher's LSD test to test the significance of the means of each variable.

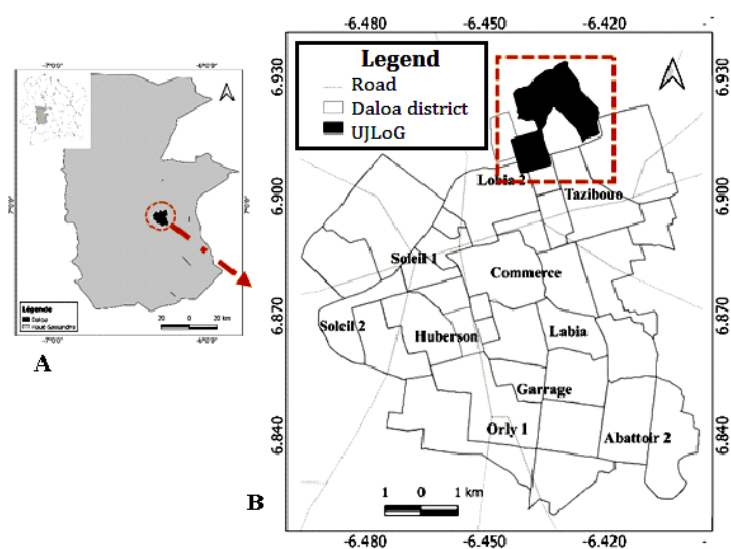

Fig. 1. Location of the study area and site (A: Haut-Sassandra region; B: City of Daloa)

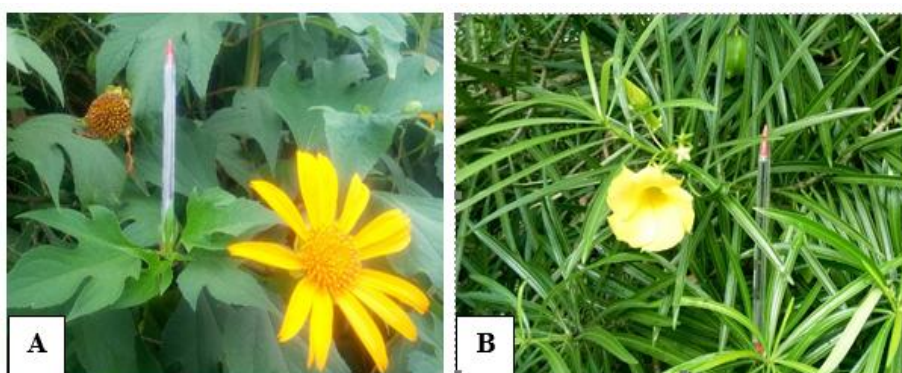

Fig. 2. Leafy and flowering branches of *Tithonia diversifolia* (A) and *Thevetia nerifolia* (B)

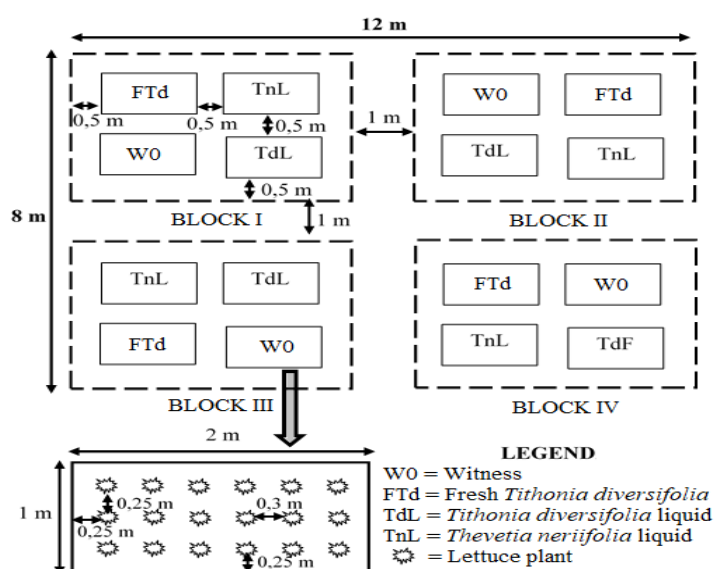

Fig. 3. Experimental device

Table 1. Fertilization program and quantity of biofertilizers provided per treatment

Treatments	Contribution of biofertilizers		
	1 week before transplanting	2 weeks after transplanting	4 weeks after transplanting
Fresh Tithonia (FTd)	3 kg/m ²	3 kg/m ²	1,5 kg/m ²
Liquid Tithonia (TdL)	0,6 L/m ²	0,6 L/m ²	0,3 L/m ²
Liquid Thevetia (TnL)	0,6 L/m ²	0,6 L/m ²	0,3 L/m ²

3. RESULTS AND DISCUSSION

3.1 Growth Parameters of Lettuce

The average height of the lettuce plants was evaluated and recorded in Table 2. The values obtained varied between 9.89 centimeter for the FTd treatment and 12.96 centimeter for the TnL treatment. The analysis of variance at the 5% threshold ($p = 0.06$) indicates that there is no significant difference between the treatments applied.

Fig. 4 shows the average lengths obtained with the different treatments. These averages varied from 7.01 centimeter to 8.10 centimeter. A highly significant difference ($p=0.003$) was observed between the treatments. The LSD test carried out at the 5% threshold made it possible to discriminate between the treatments in two distinct classes. According to this discrimination, the FTd treatment with a numerical value of 7.01 centimeter had the lowest average leaf length. On the other hand, the TdL treatment presented the high mean value (8.10 centimeter) of leaf length.

Data analysis made it possible to obtain, at the 5% threshold, average leaf widths of lettuce plants per treatment (Fig. 5). There were significant differences ($p = 0.01$) between the treatments in terms of lettuce leaf width. The highest leaf width values were obtained with the TdL (5.79 centimeter) and TnL (5.70 centimeter) treatments and the lowest with the W0 (5.15 centimeter) and FTd (5.14 centimeter) treatments.

The average number of leaves was determined as part of the study of the effects of different fertilizers (Fig. 6). ANOVA (at the 5% threshold) revealed a significant difference ($p = 0.0001$) across all treatments. The TdL and TnL treatments produced the highest leaf counts, with averages of 5.88 and 5.62 leaves, respectively. On the other hand, the lowest average value in number of leaves was obtained with the FTd treatment (4.66 leaves).

Fig. 7 shows the results of the average span values recorded with the applied biofertilizer treatments. Statistical analysis showed a highly significant effect ($p = 0.0002$) of biofertilizers. The three biofertilizer formulations tested made it possible to obtain larger measurements; 11.15 centimeter for TdL, 10.55 centimeter for TnL and 9.49 centimeter for FTd. The lowest wingspan measurement was obtained by the control treatment (W0) with an average of 9.10 centimeter.

The fertilizers used in this study improved overall all the parameters considered. All vegetative parameters; i.e. plant height, leaf length, leaf width, leaf number and wingspan of lettuce treated with Tithonia and Thevetia liquid were higher than those of control and fresh Tithonia during this trial. Statistical analyzes revealed a significant difference between the treatments. The results of the present work agree with those of Kasongo et al. [15]. These authors obtained control plants whose size is much lower than that of the fertilized plants, following the application of organic amendments to the potato. The liquid form obtained from the manure of *Tithonia diversifolia* and *Thevetia neriifolia*, would promote the decomposition of the leaves and the release of the mineral elements necessary for the plant according to Kaho et al. [8].

For Salla et al. [10], the low average values obtained for all the growth parameters with the fresh leaves of *T. diversifolia*, would be due beforehand to the time necessary for a decomposition of the leaves incorporated in the soil followed by a progressive release of the minerals before their assimilation. These results suggest that the two fertilizers of plant origin could have the same mineral elements available and improve the physico-chemical properties of the soil necessary for the good growth and development of plants. However, the natural decay time would not be favorable to the vegetative phase of short cycle plants, such as lettuce.

3.2 Parameter Yield of Lettuce at Harvest

The effect of treatments on lettuce yield was determined and is shown in Fig. 8. Statistical analysis at the 5% threshold revealed no significant difference ($p > 0.05$) between treatments. The best yields were recorded with the TdL (20.00 t/ha) and FTd (20.00 t/ha) treatments. On the other hand, the lowest yield (15.00 t/ha) was obtained from the control treatment W0.

This trial demonstrated the ability of *Tithoniadiversifolia* and *Thevetianeriifolia* to improve lettuce yield. The highest yields were obtained with treatments based on *T. diversifolia* (liquid and solid). These results are similar to those of Kahoet al. [8] on maize cultivation in Cameroon and those of Kasongoet al. [9] on soy in D.R. Congo. These authors obtained high yields using fresh *T. diversifolia* as fertilizer in their respective crops.

Table 2. Average values of average plant height per treatment

Treatments	Average plant height (centimeter)
W0	10,25 ± 6,71 ^a
FTd	9,89 ± 6,79 ^a
TdL	11,75 ± 7,9776 ^a
TnL	12,96 ± 29,32 ^a
p	0,06

W0 = Control; FTd = Tithoniafresh; TdL = Liquid Tithonia; TnL= Liquid Thevetia; p = significance level

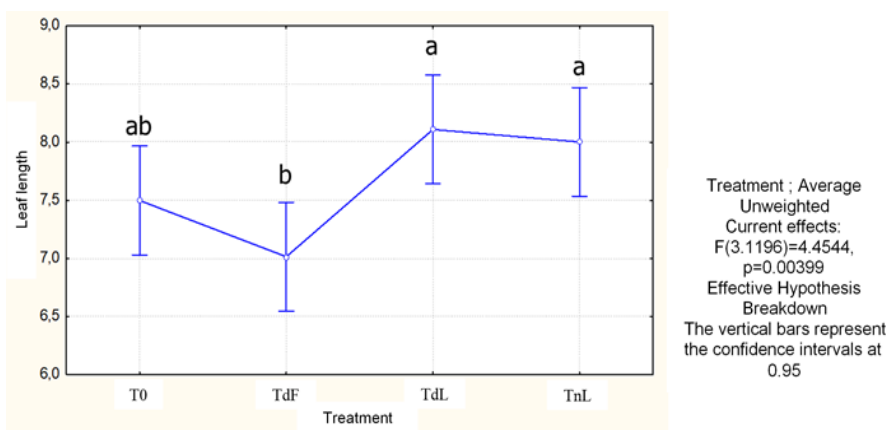

Fig. 4. Average length of lettuce plants according to treatment

W0 = Control; FTd = fresh Tithonia; TdL = Liquid Tithonia; TnL = liquid Thevetia; p = significance level

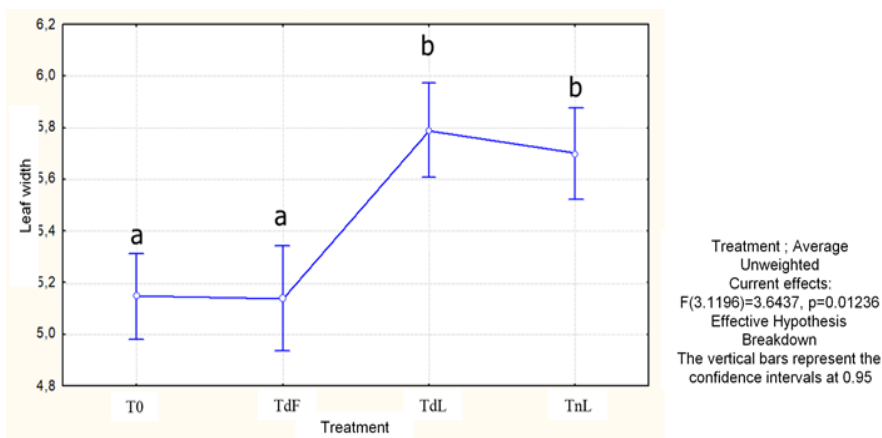

Fig. 5. Average width of lettuce plants according to treatments

W0 = Control; FTd = fresh Tithonia; TdL = Liquid Tithonia; TnL = liquid Thevetia; p = significance level

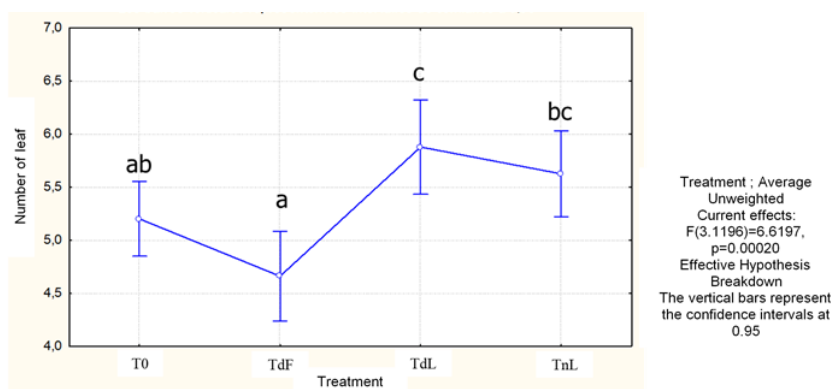

Fig. 6. Average number of leaves of lettuce plants according to the treatments
 W0 = Control; FTd = fresh Tithonia; TdL = Liquid Tithonia; TnL = liquid Thevetia; p = significance level

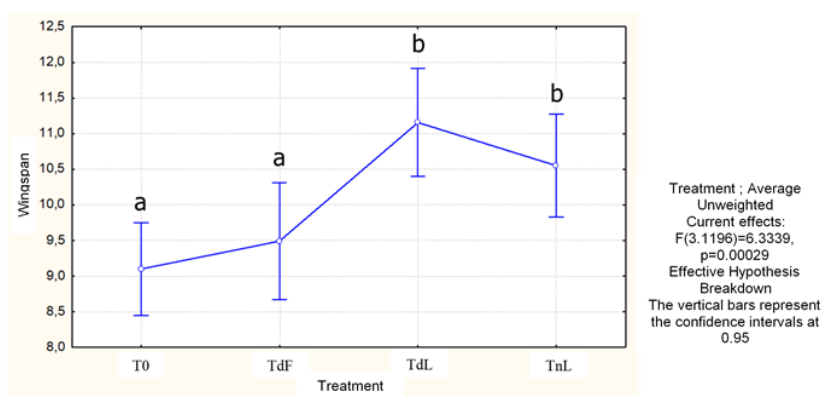

Fig. 7. Average size of lettuce plants according to treatment
 W0 = Control; FTd = fresh Tithonia; TdL = Liquid Tithonia; TnL = liquid Thevetia; p = significance level

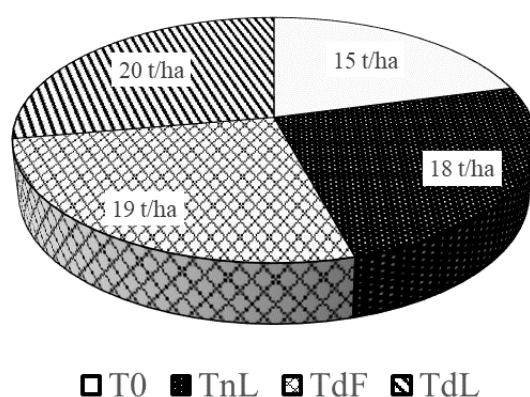

Fig. 8. Lettuce yield per treatment

W0 = Control; FTd = fresh Tithonia; TdL=Liquid Tithonia; TnL = liquid Thevetia; p = significance level

4. CONCLUSION

The present study showed that treatments based on *Tithoniadiversifolia* and *Thevetianeriifolia* significantly improved lettuce growth and yield parameters. However, the treatments with liquid Tithonia and Thevetia gave the highest average

values, considering their accelerated decomposition into manure. Although their effectiveness has not been compared to that of synthetic fertilizers as a reference, the results obtained thanks to these treatments constitute a good alternative for future studies, in particular, in the field of market gardening.

COMPETING INTERESTS

Authors have declared that no competing interests exist.

REFERENCES

1. UN 2020. Let's shape our future together. 2020. Accessed 29 August 2022. Available:<https://www.un.org/en/un75/shifting-demographics>
2. Guezere A. The obsession with living in one's own house in Lomé: What impact on spatial dynamics. *The Overseas Notebooks*. 2011;256:565-590.
3. Jama B, Palm CA, Buresh RJ, Niang AI, Gachengo C, Nziguheba G. *Tithonia* as a green manure for soil fertility improvement in Western Kenya: A review. *Agroforestry Systems*. 2000;49:201-221.
4. Dupriez H, Lenneer D. *Tropical agriculture in an African peasant environment*. Edition Terre et vie. News; 1998.
5. Useni SY, Chukiyabo KM, Tshomba KJ, Muyambo ME, Kapalanga KP, Ntumba NF, Kasangij KP, Kyungu KA, Baboy LL, Nyembo KL, & Mpundu MM. Use of recycled human waste to increase maize (*Zea mays* L.) production on a ferral soil in southeastern DR Congo. *Journal of Applied Biosciences*. 2013;(66): 5070-50811.
6. Kakai HF, Kakai AG & Tehouegnon AG. Urban agriculture and waste recovery in Benin: a sustainable development approach. *Vertigo*, 2010;10(2):1-36.
7. Nguo BP, World G, Seburiri ST. Effect of different organic fertilizers on eggplant cultivation in Saké (R.D. Congo). *Annals of UNIGOM*, 2016.
8. Kaho F, Yemefack M, Feujio-Teguefouet P, Tchanchaoung JC. Combined effect of *Tithoniadiversifolia* leaves and inorganic fertilizers on maize yields and properties of ferralitic soil in central Cameroon. *Tropicicultura*. 2011;29(1):39-45.
9. Kasongo LME, Mwamba MT, Tshipoya MP, Mukalay MJ, Useni SY, Mazinga KM & Nyembo KL. Response of the soybean crop (*Glycine max* L. (Merril) to the contribution of green biomasses of *Tithoniadiversifolia* (Hemsley) A. Gray as organic manure on a Ferralsol in Lubumbashi, R.D. Congo. *Journal of Applied Biosciences*. 2013;63:4727-4735.
10. Salla M, Abobi AHD, Coulibaly S, Traore K, Messamé Moussa Traore MM. Effects of biofertilizers based on *Tithonia diversifolia* and *Thevetianeriifolia* on lettuce production in Daloa. *Center-West of Ivory Coast. Moroccan Review of Agronomic and Veterinary Sciences*. 2022;10(3):336-340.
11. INS. General Population and Housing Census. Implementation report and presentation of the main results; 2014.
12. Zro Bi GF, Guéi AM, Nangah KY, Soro D & Bakayoko S. Statistical approach to the analysis of the variability and fertility of vegetable soils of Daloa (Côte d'Ivoire). *African Journal of Soil Science*. 2016;4 (4):328-338.
13. Ouattara YA. Etude comparative de la qualité fertilisante de deux biofertilisants (Azollacaroliniana, le compost), et du NPK sur la croissance végétative et le rendement de la tomate (*Lycopersicon esculentum*) dans la zone de Daloa (Côte d'Ivoire). Mémoire de master en sécurité alimentaire, UFR Agroforesterie, Université Jean Lorougnon Guédé de Daloa (Côte d'Ivoire); 2018.
14. Tchaniley L, Ayisah KD, Dewa Kassa KA. Effect of the combination of organic and mineral fertilizers (NPK 15-15-15 and urea) on the yield of lettuce (*Lactuca sativa* L.) in southern Togo. *Journal of Applied Biosciences*. 2020;151:15540-15549.
15. Ngoyi AN, Masanga GK, Bila HM, Yashima AY, Milambo MM, Ndjibu LN. & Baboy L.L. Effect of organic amendments on the growth and yield of potato (*Solanum tuberosum*) grown on degraded soil in the Kabinda region, Democratic Republic of Congo. *International Journal of Biological and Chemical Sciences*. 2020;14(5):1812-1819.

© 2023 Salla et al.; This is an Open Access article distributed under the terms of the Creative Commons Attribution License (<http://creativecommons.org/licenses/by/4.0>), which permits unrestricted use, distribution, and reproduction in any medium, provided the original work is properly cited.

Peer-review history:
The peer review history for this paper can be accessed here:
<https://www.sdiarticle5.com/review-history/98737>